

1 Appendix

Network Architecture The network architecture of two cross-domain attention modules is shown in Figure 1.

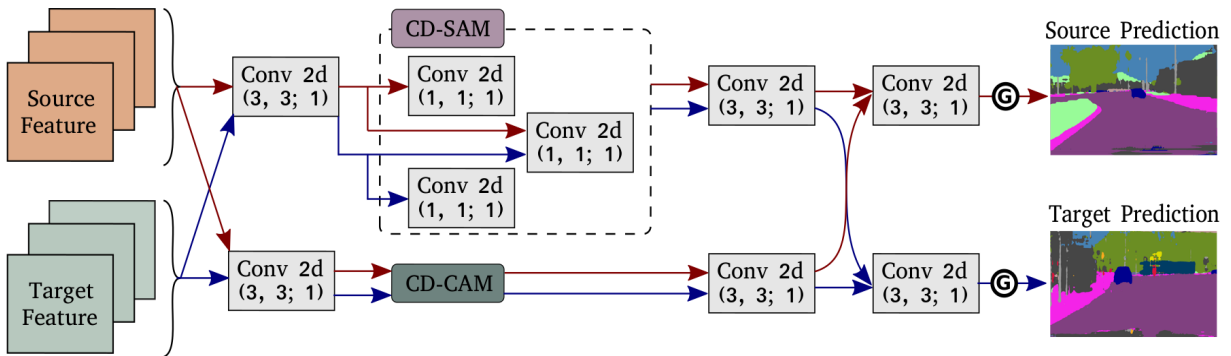

Figure 1: The network architecture of two cross-domain attention modules, where Conv 2d ($k, k; j$) indicates the 2D convolution with kernel size ($k \times k$) and stride j . The red and blue lines denote features from source and target domains, respectively.