

# Summarizing First-Person Videos from Third Persons' Points of Views

Hsuan-I Ho<sup>1</sup>, Wei-Chen Chiu<sup>2</sup>, and Yu-Chiang Frank Wang<sup>1</sup>

<sup>1</sup> Department of Electrical Engineering, National Taiwan University, Taiwan  
{b01901029, ycwang}@ntu.edu.tw

<sup>2</sup> Department of Computer Science, National Chiao Tung University, Taiwan  
walon@cs.nctu.edu.tw

**Abstract.** Video highlight or summarization is among interesting topics in computer vision, which benefits a variety of applications like viewing, searching, or storage. However, most existing studies rely on training data of third-person videos, which cannot easily generalize to highlight the first-person ones. With the goal of deriving an effective model to summarize first-person videos, we propose a novel deep neural network architecture for describing and discriminating vital spatiotemporal information across videos with different points of view. Our proposed model is realized in a semi-supervised setting, in which fully annotated third-person videos, unlabeled first-person videos, and a small number of annotated first-person ones are presented during training. In our experiments, qualitative and quantitative evaluations on both benchmarks and our collected first-person video datasets are presented.

**Keywords:** Video Summarization · First-Person Vision · Transfer Learning · Metric Learning

## 1 Introduction

Wearable and head-mounted cameras have changed the way how people record and browse videos. These devices enable users to capture life-logging videos without intentionally focus on particular subjects. Thus, the resulting first-person videos (or egocentric videos) would exhibit very unique content and properties when comparing to those of third-person ones. As pointed out by Molino *et al.* [18], the lack of sufficient structural information and repetitive content for first-person videos would limit viewing quality. Therefore, it is desirable to be able to highlight or summarize such videos for improving user viewing experiences.

With the goal of encapsulating informative segments from videos, video summarization aims at identifying the highlight video segments. Existing approaches for video summarization either select the most representative video segments [8,16] or detect particular or pre-defined visual structures or objects as summarized outputs [13,14,15]. With the recent development of deep learning, a recent work [28] successfully utilized deep neural networks for first-person

video summarization, by using a pre-collected and annotated first-person video dataset.

Nevertheless, it is difficult to collect a large amount of fully annotated first-person video data (note that the dataset in [28] is not publicly available). To address such limitations, the technique of transfer learning becomes an alternative solution. To be more precise, it is possible for one to learn from annotated third-person videos and aim at transferring the learned model to summarize the first-person ones. However, since significant differences of visual appearance can be expected between third and first-person videos, how to apply and adapt existing third-person video summarization approaches would be a challenging task. Moreover, a satisfying first-person video summary should consist of segments important to both the recorder and the viewer. Without observing any annotated first-person video revealing such information, it would be difficult to learn an effective model for solving the corresponding task.

Existing transfer learning works have been focusing on alleviating the domain shift (or dataset bias) across data domains [19]. With the recent success of deep learning, architectures of deep neural networks have also been utilized to solve similar problems [21]. Recent deep learning based video summarization approaches like [11,17,30] did not explicitly address this issue. To advance transfer learning for first-person video summarization, one could utilize fully annotated third-person videos plus a number of annotated first-person videos for training their models. In order to increase the training set size of first-person videos without label information, one could further extend the above supervised domain adaptation setting to a more challenging yet practical semi-supervised one. That is, additional unlabeled first-person videos can be also presented during training. As a result, one not only requires to alleviate the domain (viewpoint) bias between first and third-person videos, how to learn deep neural networks in a semi-supervised setting needs to be also addressed.

In this paper, we propose a deep learning framework which performs cross-domain feature embedding and transfers highlight information across video domains. More specifically, our network architecture jointly performs domain adaptation (across third-and first-person videos) in a semi-supervised setting. That is, in addition to third-person videos with fully annotated highlight scores, first-person videos are also presented during training, while only a small portion of them are with ground-truth scores. Moreover, we further integrate a sequence-to-sequence model based on recurrent neural networks (RNN), which allows the exploitation of long-term temporal information for improved summarization.

In summary, our contributions are threefold: 1) By reducing the semantic gap between third and first-person videos, our proposed network transfers informative spatiotemporal features across video domains to perform first-person video summarization; 2) our network is able to handle unlabeled data during adaptation, which not only allows our model to be trained in a semi-supervised setting, possible overfitting due to a small amount of annotated first-person video data can be also alleviated; 3) in addition to the use of SumMe [7] dataset, we

collect a larger-scale first-person video dataset for further evaluation, which is now available<sup>3</sup>.

## 2 Related Works

**First-Person Video Summarization** Summarizing first-person videos has attracted the computer vision community in recent years [2,4,18]. Most existing approaches follow a basic workflow consisting of (1) visual feature extraction and (2) keyframe selection or scene segmentation, while the latter is typically subject to pre-defined criteria. For example, Lee *et al.* [13,14] select video frames containing important subjects and objects alongside visual diversity, while Betadapura *et al.* [3] look for artistic properties in vacation-related videos. Lin *et al.* [15] train a context-specific highlight detector for each type of egocentric videos, which enables online summarization and solves the problem of data storage. Xu *et al.* [27] exploit gaze information to predict the attention given to video segments, resulting summarization that reflects the recorder preferences. However, the above methods are mainly applied to specific video contexts (e.g., daily live or cooking videos). Although a recent work by Yao *et al.* [28] learns an associated ranking function via deep metric learning to score video segments of 15 categories, it requires an enormous number of fully-annotated first-person videos (over 50 hrs) for training. This is why a semi-supervised transfer learning framework (as ours) for video summarization is practically preferable, with the goal of leveraging information across video domains for improved summarization.

**Deep Learning for Video Summarization** Some recent deep-learning based methods approach video summarization by solving a sequence-to-sequence problem, in which the video frames are encoded by Recurrent Neural Network (RNN) schemes. For example, Zhang *et al.* [30] propose a summarization model based on a bidirectional Long Short Term Memory (biLSTM) framework, which is trained on videos with annotated importance scores for keyframe selection. They additionally apply determinantal point process (DPP) to enhance the diversity of the chosen keyframes. Ji *et al.* [11] further extend such biLSTM models by integrating the attention mechanism. Their model considers temporal information in finer granularity when decoding the feature vectors of video segments generated by biLSTM.

Although supervised approaches exhibit promising video summarization results, existing datasets (with ground-truth data) for video summarization [7,23] are generally with smaller scales. For learning effective summarization models, it would be desirable to have a large number of labeled videos for training purposes. Several works thus attempt to utilize various techniques in order to address this issue. For example, Panda *et al.* [20] collect weakly annotated videos from YouTube 8M [1] and train their summarization model with auxiliary labels of

---

<sup>3</sup> The dataset and code is available on: <https://github.com/azuxmiyo/fpvsu>

**Table 1.** Comparisons of existing video summarization datasets.

Dataset	Type	Length	# of videos	Annotation/Score	Description
UT Ego [13]	1st-person	17 hr	4	Video frames which contain important people and objects	- Videos of daily activities in a uncontrolled setting
VideoSet [29]	1st-person	>60 hr	13	Textual description for each 5-seconds video segment	- Provide textual labels for UT Ego [13] and DisneyWorld [6] - <b>Not publicly available</b>
EgoSum+gaze [27]	1st-person	>15 hr	21	5 ~ 15 events selected by 5 camera wearers	- Daily lives videos together with gaze data - <b>Not publicly available</b>
Yao <i>et al.</i> [28]	1st-person	>100 hr	600	Fully annotated frame-level scores from 12 annotators	- 15 categories of GoPro sports videos mined from YouTube - <b>Not publicly available</b>
SumMe [7]	3rd-person	50 min	20	Fully annotated frame-level scores from at least 15 annotators	- Raw user videos containing interesting events
	1st-person	14 min	5		
TvSum [23]	3rd-person	3 hr 30 min	50	Fully annotated frame-level scores from 20 annotators	- 50 YouTube videos in 10 categories from the TRECVID MED task
Proposed	1st-person	7 hr 56 min	98	Fully annotated frame-level scores from at least 10 annotators	- 14 categories of GoPro viewer-friendly videos selected from YouTube

activity classes; Sun *et al.* [24] train their highlight classifiers by utilizing a collection of YouTube videos that have been edited as positive training data, while the negative ones are retrieved from raw videos. Alternatively, Gygli *et al.* [9] present summarization models by collecting massive training pairs mined from GIF image websites. By advancing sequential generative adversarial networks, Mahasseni *et al.* [17] perform video summarization by predicting video keyframe distribution.

Nevertheless, the above approaches generally focus on summarizing third-person videos, or those with mixed type of videos [7,23] (i.e., no distinction between third and first-person ones). As noted above, highlighting first-person videos would be particularly challenging due to significant changes in visual content and appearances (plus, due to the lack of a sufficient amount of annotated training data). This is the reason why we choose to address first-person video summarization in a semi-supervised setting, and propose deep transfer learning techniques for solving this problem.

**Datasets for Video Summarization** Finally, we summarize the characteristics of existing datasets for both first-person and third-person video summarization in Table 1. UT Ego [13] annotates the keyframes including important objects and people in daily lives videos. VideoSet [29] provides extra textual labels for videos in UT Ego [13] and Disneyworld [6], including tools for summarization evaluation. EgoSum+gaze [27] consists of shot-level annotations obtained from camera wearers together with their gaze information. However, the context of the above first-person datasets are very limited (e.g., daily lives, cooking, etc. activities). Moreover, it is difficult for viewers to obtain frame-level importance scores due to their long duration and redundancy.

Yao *et al.* [28] first propose a large-scale dataset including frame-level annotations for various sports videos mined from YouTube. In contrast to two widely used dataset SumMe [7] and TvSum [23], most first-person videos mined from YouTube are either over-edited or overlong, which can result in very dif-

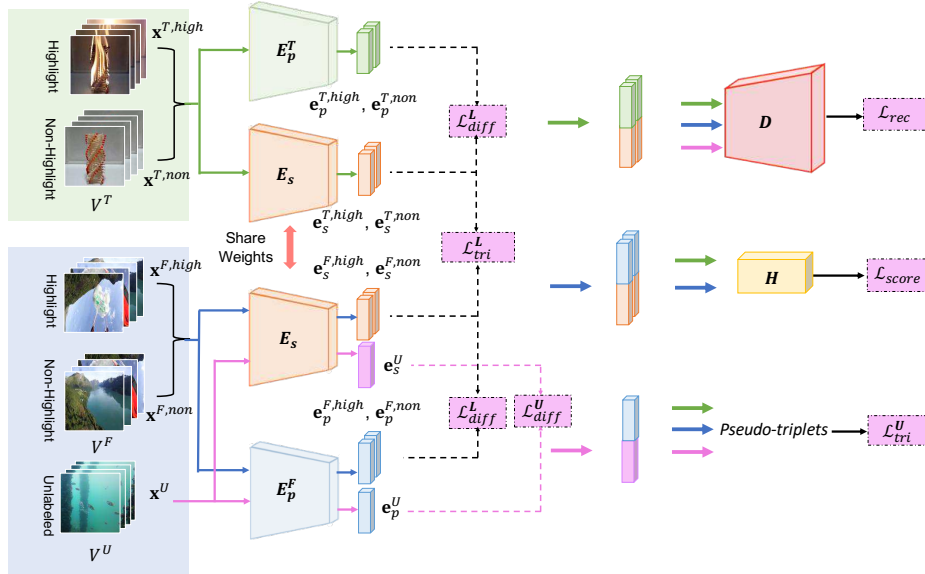

**Fig. 1.** Our first-person video summarization framework via semi-supervised domain adaptation. Note that fully annotated third-person videos  $V^T$ , unlabeled first-person videos  $V^U$ , plus a number of annotated first-person ones  $V^F$  are presented during training. We have  $\mathbf{x}$ ,  $\mathbf{e}_s$ , and  $\mathbf{e}_p$  denote the input, *shared* and *private* features, respectively.

ferent viewpoints across videos, plus frame discontinuity and annotation biases within the dataset. It is worth noting that, most first-person datasets for video summarization are not publicly available, this is the reason why one of our major contributions is to collect and release a first-person video dataset including viewer-friendly videos and unbiased importance scores for research purposes.

### 3 Proposed Framework

For the sake of completeness, we first explain the notations in this paper. We have an annotated video collection including a set of third-person videos  $V^T = \{V_1^T, \dots, V_M^T\}$  and few first-person videos  $V^F = \{V_1^F, \dots, V_N^F\}$ , where  $M$  and  $N$  denote the numbers of third- and first-person videos respectively (where typically  $M > N$ ). Their corresponding annotations (i.e., importance scores) at the frame-level are  $S^T = \{S_1^T, \dots, S_M^T\}$  and  $S^F = \{S_1^F, \dots, S_N^F\}$ . In addition, we have another set of first-person videos  $V^U = \{V_1^U, \dots, V_K^U\}$  without any annotation of importance scores, with the number of videos  $K \gg N$ . The goal of our work is to bridge the semantic gap across  $V^T$ ,  $V^F$  and  $V^U$ , so that the learned model can be applied for first-person video summarization.

The architecture of our proposed method is shown in Fig. 1, which consists of network components for cross-domain feature embedding and summarization.

The highlights of our method include: 1) our domain separation architecture learns shared and private features across video domains, while adapting cross-domain highlight information for summarization; 2) a self-learning scheme for leveraging unlabeled first-person video data, so that our model can be trained in a semi-supervised setting; and 3) our highlight detection network for exploiting long-term temporal information to improve final summarization. Details of our framework will be described in the following subsections.

### 3.1 Cross-Domain Feature Embedding

To adapt information across video domains for highlighting a particular video domain of interest, the first stage of our proposed network performs cross-domain feature embedding. More specifically, we aim at retrieving and transferring representative highlight information across third and first-person videos, while suppressing irrelevant features in each domain. This is achieved by performing cross-domain feature embedding via a domain separation structure. Inspired by [5], our network component for domain separation decomposes feature representations into of two subspaces: a *shared* subspace across video domains to extract domain-invariant information, and *private* subspaces which are unique to each domain for describing domain-specific properties.

Given video segments with fixed-length, i.e.,  $X^T = \{\mathbf{x}_1^T, \dots, \mathbf{x}_m^T\}$  and  $X^F = \{\mathbf{x}_1^F, \dots, \mathbf{x}_n^F\}$  from  $V^T$  and  $V^F$ , respectively, we view such segments as the basic elements in our framework for capturing video spatiotemporal information. The shared encoder  $E_s$  in Fig. 1 encodes  $\mathbf{x}^T, \mathbf{x}^F$  into domain-invariant representations  $\mathbf{e}_s^T, \mathbf{e}_s^F$ , while the private encoders  $E_p^T$  and  $E_p^F$  embed them into domain-specific features  $\mathbf{e}_p^T$  and  $\mathbf{e}_p^F$ . These encoders are jointly learned with a decoder  $D$  and two explicit loss functions: the reconstruction loss  $\mathcal{L}_{rec}^L$  and difference loss  $\mathcal{L}_{diff}^L$ . Note that,  $\mathcal{L}_{rec}^L$  encourages the reconstruction of  $\mathbf{x}$  by decoder  $D$  from the features concatenating shared and private representations  $\mathbf{e} = \text{concat}(\mathbf{e}_s, \mathbf{e}_p)$ , which can be written as:

$$\mathcal{L}_{rec}^L = \sum_{i \in \{F, T\}} \|f_D(\mathbf{e}^i) - \mathbf{x}^i\|_2^2. \quad (1)$$

As for the difference loss  $\mathcal{L}_{diff}^L$ , it is imposed on the orthogonality between  $\mathbf{e}_s$  and  $\mathbf{e}_p$ , and thus enforces  $E_s$  and  $E_p$  to capture different aspects of information (shared and private ones) from  $\mathbf{x}$ . Thus,  $\mathcal{L}_{diff}^L$  is defined as:

$$\mathcal{L}_{diff}^L = \|\mathbf{E}_p^{T\top} \mathbf{E}_s^T\|_F^2 + \|\mathbf{E}_p^{F\top} \mathbf{E}_s^F\|_F^2, \quad (2)$$

where  $\mathbf{E}_p^T$  and  $\mathbf{E}_s^T$  are the matrices consisted of private and shared features of the third-person video segments in a batch. Likewise,  $\mathbf{E}_p^F$  and  $\mathbf{E}_s^F$  denote the matrices for the corresponding first-person embedded features. Exploiting the above domain separation architecture allows us to mitigate domain differences via shared feature embedding across video domains, and meanwhile retains sufficient domain-specific characteristic in the private subspaces for each domain.

Despite the above use of domain separation components for suppressing feature differences across video domains, there is *no* guarantee the shared encoder  $E_s$  captures the semantics of highlight information from input videos. Hence, we further advance deep metric learning with the triplet network [10,22] for improved feature embedding. This not only allows us to better describe videos over third and first-person views but also reflects and shares highlight information across video domains for later summarization purposes.

To achieve the above goal, we divide the cross-domain videos in shared features with ground-truth score annotation into highlight and non-highlight subsets:  $\{\mathbf{e}_s^{T,high}, \mathbf{e}_s^{T,non}\}$  and  $\{\mathbf{e}_s^{F,high}, \mathbf{e}_s^{F,non}\}$ , where  $\mathbf{e}_s^{T,high}$  and  $\mathbf{e}_s^{T,non}$  relate to the highlight and non-highlight third-person video subsets, respectively. Similarly, we have first-person video subsets  $\{\mathbf{e}_s^{F,high}, \mathbf{e}_s^{F,non}\}$ . To jointly eliminate video domain differences and adapt highlight information across domains, the triplets are built from a set of features  $\{\mathbf{e}_s^{T,high}, \mathbf{e}_s^{T,non}, \mathbf{e}_s^{F,high}, \mathbf{e}_s^{F,non}\}$  to include feature pairs extracted from within and across-domain video data. Take  $\{\mathbf{e}_s^{T,high}, \mathbf{e}_s^{T,non}, \mathbf{e}_s^{F,high}\}$  as examples, the corresponding triplet loss is calculated as:

$$\mathcal{L}_{tri}^L = \max\{0, \mathcal{M} - \mathcal{D}_{cos}(\mathbf{e}_s^{T,high}, \mathbf{e}_s^{T,non}) + \mathcal{D}_{cos}(\mathbf{e}_s^{F,high}, \mathbf{e}_s^{T,high})\}, \quad (3)$$

where  $\mathcal{D}_{cos}(\mathbf{e}, \mathbf{e}') = 1 - \frac{\mathbf{e} \cdot \mathbf{e}'}{\|\mathbf{e}\|_2 \|\mathbf{e}'\|_2}$  returns the distance between the embedding features, and  $\mathcal{M}$  denotes the margin for metric learning. Note that such losses are calculated for all triplets from within and cross-video data.

### 3.2 Self-Learning with Unlabeled First-Person Videos

The feature embedding network described in Sect. 3.1 allows us to identify domain-invariant and domain-specific features across video domains. However, since the number of labeled first-person videos is generally much smaller than that of third-person ones, it would be desirable to further exploit unlabeled first-person ones, so that possible overfitting can be alleviated.

In our proposed network, we thus introduce a *self-learning* component for addressing this task. As illustrated in Fig. 1, unlabeled segments of first-person videos pass through the embedding network, resulting in feature vectors  $\mathbf{e}_p^U, \mathbf{e}_s^U$ . The reconstruction loss  $\mathcal{L}_{rec}^U$  and difference loss  $\mathcal{L}_{diff}^U$ , which are identical to  $\mathcal{L}_{rec}^L$  and  $\mathcal{L}_{diff}^L$  respectively but applied for unlabeled  $\mathbf{e}^U$  and  $\mathbf{E}^U$ , are also used in training:

$$\mathcal{L}_{rec}^U = \|f_D(\mathbf{e}^U) - \mathbf{x}^U\|_2^2, \mathcal{L}_{diff}^U = \|\mathbf{E}_p^{U\top} \mathbf{E}_s^U\|_F^2. \quad (4)$$

To further utilize unlabeled first-person videos together with the annotated cross-domain data for improved cross-domain feature embedding, we extend the above learning scheme by generating pseudo triplets, which allows us to finetune the above cross-domain embedding network. To be more precise, in a subset built upon samples from  $\{\mathbf{e}^T, \mathbf{e}^F\}$ , the farthest and nearest features with respect to each reference  $\mathbf{e}^U = \text{concat}(\mathbf{e}_s^U, \mathbf{e}_p^U)$  would be viewed as the negative pair  $\mathbf{e}^-$  and positive pair  $\mathbf{e}^+$  for  $\mathbf{e}^U$ , thus forming pseudo triplets. Therefore, without

observing ground-truth annotation scores, the loss of such a pseudo triplet  $\mathcal{L}_{tri}^U$  can be calculated for each unlabeled first-person video:

$$\mathcal{L}_{tri}^U = \max \{0, \mathcal{M} - \mathcal{D}_{cos}(\mathbf{e}^U, \mathbf{e}^-) + \mathcal{D}_{cos}(\mathbf{e}^U, \mathbf{e}^+)\}. \quad (5)$$

With the above self-learning strategy, we are now able to jointly exploit both supervised and unlabeled video data during training, so that network components  $E_p^F$ ,  $E_s$  and  $D$  can be updated accordingly.

### 3.3 From Segment to Sequence Based Highlight Detection

From the above subsections, we see that the first stage of our network performs feature embedding across video domains in a semi-supervised setting, while both representation and discriminative highlight information are preserved in the feature space. Since the focus of our network is to perform first-person video summarization, we finally introduce a highlight detection network. As depicted in Fig. 1, this would additionally enforce the resulting joint features of first-person videos to exhibit sufficient highlight information.

With our use of highlight and non-highlight scores, the introduced highlight detection network serves as a binary classifier, which distinguishes between the associated video segments accordingly. Thus, we do not consider ranking loss as [9,24,28] did. Instead, following [17], we apply classification loss for our highlight detection model.

To detail this highlight detection process, we have concatenated features  $\{\mathbf{e}_1, \dots, \mathbf{e}_B\}$  as inputs to the highlight detection network  $H$  for predicting the importance scores  $\hat{\mathbf{s}}_i = f_H(\mathbf{e}_i)$ . Note that  $\mathbf{e}_i = \text{concat}(\mathbf{e}_{p,i}, \mathbf{e}_{s,i})$ , and  $B$  as the number of instances in each batch. The scoring loss between the predicted and ground-truth scores is calculated as:

$$\mathcal{L}_{score} = -\frac{1}{B} \sum_{i=1}^B \mathbf{y}_i \cdot \log(\hat{\mathbf{s}}_i), \quad (6)$$

where each ground-truth scores  $s_i$  are converted to 2-D one-hot vectors  $\mathbf{y}_i = (0, 1) \vee (1, 0)$ , and the network  $H$  returns a 2-D softmax prediction  $\hat{\mathbf{s}}_i$  instead of an 1-D scalar  $\hat{s}_i$ .

To extend the above segment-based video highlight detection into sequence-based prediction, we further extend the proposed network architecture to a sequence level, i.e., the feature output of the embedding network is now served as the input to a recurrent neural network (RNN). As suggested in [11,17,30], integration with such RNN-based components allows one to observe long-term dependency between segments within a video sequence. While recent RNN-based models can be easily applied and integrated into our framework (e.g., LSTM-based models [30], adversarial LSTM networks [17], and attention-based encoder-decoder networks [11]), we particularly take the video summarization LSTM (vsLSTM) in [30] for our use. We note that vsLSTM consists of a bidirectional LSTM (biLSTM) cell followed by a single-hidden-layer MLP. The biLSTM cell



takes a sequence of concatenated features  $\mathcal{E} = \{\mathbf{e}_1, \dots, \mathbf{e}_t\}$  as inputs and returns both forward hidden states  $\mathbf{h}^{forward} = \{\vec{\mathbf{h}}_1, \dots, \vec{\mathbf{h}}_t\}$  and backward hidden states  $\mathbf{h}^{backward} = \{\overleftarrow{\mathbf{h}}_1, \dots, \overleftarrow{\mathbf{h}}_t\}$ . These observed hidden states would exploit and preserve semantic information across time periods. Upon the introduction of LSTM-based models, a single-hidden-layer MLP can be directly deployed for predicting the importance scores  $\hat{\mathbf{s}} = \{\hat{\mathbf{s}}_1, \dots, \hat{\mathbf{s}}_t\}$  with inputs  $\mathbf{h}^{forward}$ ,  $\mathbf{h}^{backward}$ , and  $\mathcal{E}$ . As a result, the scoring loss for updating vsLSTM can be calculated via (6).

### 3.4 Learning of Our Network

It is worth noting that, our proposed network allows end-to-end training, which updates the parameters for each component by calculating the following loss:

$$\mathcal{L}_{total} = \mathcal{L}_{tri} + \alpha \cdot \mathcal{L}_{rec} + \beta \cdot \mathcal{L}_{diff} + \gamma \cdot \mathcal{L}_{score}, \quad (7)$$

where  $\alpha, \beta, \gamma$  are hyperparameters that control the interaction of overall loss. Except for  $\mathcal{L}_{score}$  which relies on video data with ground-truth scores, the remaining losses are calculated and summed over labeled and unlabeled data.

As for the learning of sequence-based highlight detection network, a two-stage training scheme is implemented. That is, we first train the feature embedding network using video segment pairs as shown in Fig. 1 (i.e., segment-based highlight detection network), followed by jointly training of RNN and the resulting network using consecutive video segments as inputs.

## 4 Experiments

### 4.1 Datasets

We now describe the datasets (including the one we collect) for experiments. Two publicly available datasets with full annotations, **SumMe** [7] and **TVSum** [23], are recently used to evaluate the performance of video summarization task. Both cover a variety of video contexts for summarization purposes. **SumMe** consists of 25 user videos with a length varying from 1 to 6 minutes, in which the annotations of frame-level importance scores are provided. Within this dataset, there are five first-person videos, “Base jumping, Bike Polo, Scuba, Valparaiso Downhill, Uncut Evening Flight”, which are applied as test data for quantitative evaluation and comparisons. On the other hand, **TVSum** consists of 50 third-person videos collected from YouTube, and each of them is annotated with frame-level importance scores. The videos in this dataset are viewed as the third-person labeled data for our training purposes.

Nevertheless, the number of first-person videos in SumMe is far from sufficient for training effective deep learning models for summarization. Thus, following the procedure of [28], we additionally create a new first-person dataset containing various categories of first-person videos from YouTube along with corresponding frame-level importance scores.

**Table 2.** Descriptions and properties of video datasets considered in the experiments

Dataset	Video type	Total length	# of videos	Usage	Annotations
SumMe	1st-person	14 min	5	Testing	Yes
	3rd-person	50 min	20	Training ( $V^T$ )	Yes
TvSum	3rd-person	210 min	50	Training ( $V^T$ )	Yes
FPVSum	1st-person labeled	162 min	56	25% Training ( $V^F$ ) 55% Training ( $V^U$ ) 20% Testing	Yes
	1st-person unlabeled	314 min	42	Training ( $V^U$ )	None

During the collection of the first-person videos, we found that a large number of such videos on YouTube are not raw videos but edited ones, consisting of obvious frame discontinuity (selected/edited by users), transitions of point-of-view, and unrelated contents. Thus, they cannot be directly applied and added to the data collection for training/testing. Another observation is about the annotation collection. We observe that most annotators would lose concentration on assigning scores for long videos. Therefore, we collect a first-person video summarization dataset **FPVSum** with a total number of 98 videos. Excluding the edited or discontinuous videos, our collected video data are from 14 categories with varying lengths (over 7 hours in total). For each category, about 35% of the video sequences are annotated with ground-truth scores by at least 10 users, while the remaining are viewed as the unlabeled ones.

Complete discussions and comparisons of the datasets considered are listed in Table 2. We note that, when evaluating the performance of first-person video summarization, only our proposed model can be realized in a semi-supervised setting, while existing baseline and state-of-the-art approaches cannot handle unlabeled first-person videos during training.

## 4.2 Experimental Setup

**Evaluation Metrics** We follow the criteria used in [17,30] for video summarization evaluation, with the length of video summaries less than 15% of the total length of the original video. Let  $\mathcal{A}$  be the set of generated summaries, and  $\mathcal{B}$  is the set of video segments selected by user-annotated importance scores, the resulting precision  $\mathcal{P}$  and recall  $\mathcal{R}$  are defined as:

$$\mathcal{P} = \frac{\text{total overlap duration of } \mathcal{A} \text{ and } \mathcal{B}}{\text{total duration of } \mathcal{A}}, \quad (8)$$

$$\mathcal{R} = \frac{\text{total overlap duration of } \mathcal{A} \text{ and } \mathcal{B}}{\text{total duration of } \mathcal{B}}. \quad (9)$$

Thus, the F-measure is computed as  $\mathcal{F} = 2 \times \mathcal{P} \times \mathcal{R} / (\mathcal{P} + \mathcal{R}) \times 100\%$ . In addition, we further calculate the area-under-curve (AUC) values based on the resulting precision-recall curves, which allow us to perform detailed comparisons with respect to different lengths of summaries.

**Methods of Interest** We compare our work with four baselines (noted as **Random**, **Uniform**, **DSN** [5] and **C3D** [26]) and two state-of-the-art supervised video summarization models: **TDCNN** [28] and **vsLSTM** [30]. We first describe sequentially how the four baselines are obtained.

- **Random**: 15% of segments from each test video are randomly sampled as the highlight.
- **Uniform**: Instead of random sampling, 15% of segments from each test video are equidistantly selected as the highlight.
- **DSN**: The direct use of domain separation networks (DSN) [5] for performing cross-view video summarization.
- **C3D**: We extract C3D [26] pre-trained features for each video segment. A highlight classifier taking C3D features as the inputs is trained by the classification loss (6). The segments with top 15% prediction scores in each video are selected as the highlight outputs.

As for the two state-of-the-art methods, their original objectives and experimental settings are different from our semi-supervised one. Thus, we cannot directly report and compare their performances. Instead, we implement their works with the following settings for fair comparisons.

- **TDCNN**: Although [28] originally designs a two-stream network that exploits two visual features (i.e., AlexNet [12] and C3D) in their model, we compare TDCNN (C3D) only in our experiments for the sake of fairness. We train a temporal highlight detection network which is built upon a 6-layers fully connected Siamese network and outputs importance scores. The loss function for the TDCNN classifier is defined as  $\mathcal{L}_{pair} = \max\{0, 1 - s(\mathbf{x}^{high}) + s(\mathbf{x}^{non})\}$ , where  $s(\mathbf{x}^{high})$  and  $s(\mathbf{x}^{non})$  are the scores of highlight and non-highlight segments. The positive and negative pairs of training data for learning the Siamese network of TDCNN classifier is produced by following the same criteria described in Sect. 3.1.
- **vsLSTM**: As shown in [30], it is implemented as an architecture of stacking a video feature extractor, a biLSTM with 256 hidden units, and a single-hidden-layer MLP, where the parameters of vsLSTM are learned by using the mean squared loss. Note that the original GoogLeNet [25] feature extractor is now replaced by the same C3D architecture. We further experiments another variant of vsLSTM using classification loss as (6), which is utilized in [17].

Both TDCNN and vsLSTM models are trained with  $V^T$  and  $V^F$ , and the resulting summaries are selected from segments with top 15% scores. In addition, we implement another two variants of our approach for controlled experiments:

- **Ours w/o  $V^U$** : We train our model in Fig. 1 with supervised training data  $V^T$  and  $V^F$  only, i.e., a fully-supervised version without observing unlabeled first-person videos.
- **Ours (non-sequential)**: Instead of RNN, we apply a 2-layer fully connected network as the highlight detection network in Fig. 1. Note that this variant is applicable to both fully-supervised and semi-supervised settings.

**Table 3.** Performance evaluation and comparisons on first-person video summarization in terms of F-measures and AUC values. Note that only Ours utilizes unlabeled first-person videos during training, while vsLSTM+ replaces its original MSE loss by our classification loss.

Method		F-measure		AUC value	
		SumMe	FPVSum	SumMe	FPVSum
Baseline	Random	16.312	15.071	—	—
	Uniform	15.053	15.670	—	—
	DSN [5]	22.658	19.345	0.2075	0.1662
	C3D [26]	26.945	19.595	0.2091	0.1938
Non-sequential	TDCNN [28]	28.623	31.174	0.2340	0.2658
	Ours w/o $V^U$	35.272	37.098	0.2489	0.2904
	<b>Ours</b>	<b>38.649</b>	<b>38.409</b>	<b>0.2733</b>	<b>0.2962</b>
Sequential	vsLSTM [30]	29.850	19.901	—	—
	vsLSTM+	31.468	26.204	0.2421	0.2266
	Ours w/o $V^U$	35.980	37.366	—	—
	<b>Ours</b>	<b>41.991</b>	<b>38.572</b>	<b>0.3165</b>	<b>0.3120</b>

### 4.3 Quantitative Evaluation

**Comparisons** Table 3 summarizes the quantitative results of our framework, baselines, and the state-of-the-art video summarization algorithms. When comparing non-sequential based methods (including baselines), our model produced favorable results due to learning of cross-domain feature embedding and exploitation of unlabeled training data  $V^U$ . Recent approaches of C3D and TDCNN were not able to achieve comparable results due to their lack of ability in learning from data across video domains. We also observe that the direct use of DSN to summarize videos across data domains without exploiting any cross-domain label information could not yield satisfactory performances.

We note that the use of our proposed model without observing unlabeled first-person video training data (i.e., **Ours w/o  $V^U$**  in Table 3) still performed against the above state-of-the-art methods. This again verifies the effectiveness of our cross-domain embedding framework. As shown in Table. 3, the full version of our method achieved the best performance, which was above those reported by recent recurrent models of vsLSTMs. This is due to the fact that vsLSTM only takes C3D features as inputs, and is not designed to deal with cross-domain video data.

**Analysis of our Network Design** We now perform controlled experiments using variants of our model in the non-sequential setting. As noted in Table 4, Ours<sup>†</sup> denotes our model using only shared encoder to describe cross-domain data, and Ours<sub>ranking</sub>/Ours<sub>MSE</sub> are the ones using the associated losses, which were suggested in [9,28,30]. Finally, Ours\* represents our model without enforcing the pseudo triplet loss in (5), while Ours\*\* indicates the supervised version of our model (i.e., without observing any unlabeled first-person videos). From

**Table 4.** Analysis of our network design and settings. Note that Ours<sup>†</sup> indicates our model without using any private encoders, Ours<sub>ranking</sub>/Ours<sub>MSE</sub> denote the uses of ranking and MSE losses as the scoring loss in our model, Ours\* is the version excluding the pseudo triplet loss  $\mathcal{L}_{tri}^U$ , and Ours\*\* represents the version without observing unlabeled data  $V^U$ .

Method	Cross-domain embedding		Scoring losses		Unlabeled videos		Ours
	TDCNN [28]	Ours <sup>†</sup>	Ours <sub>ranking</sub>	Ours <sub>MSE</sub>	Ours*	Ours**	
<b>SumMe</b>	28.623	29.754	28.435	29.078	34.252	35.272	<b>38.649</b>
<b>FPVSum</b>	31.174	31.020	34.007	36.046	35.485	37.098	<b>38.409</b>

the results listed in Table 4, it is clear that our full model achieved the best performance performed. Thus, our model design and integration of the above components are desirable for cross-domain video summarization.

#### 4.4 Example Visualization Results

Fig. 2 shows example summarization results of a challenging first-person test video “Valparaiso Downhill” in SumMe dataset (with ground-truth scores provided). This video is 3-minute long recorded by a camera mounted on a helmet. It is a typical first-person video since the video content reflects the motion of the recorder (i.e., the bike rider) and no specific objects are intentionally focused. The blue bars in Fig. 2 indicate frame-level ground-truth scores annotated by users. The interval colored in green, red and yellow correspond to summaries generated by our model, vsLSTM, and TDCNN, respectively. The red horizontal lines represent the threshold for splitting highlight and non-highlight parts, as described in Sect. 3.1.

It is worth noting that, there are two particular actions, “jumping” and “going downstairs”, in this video. These two action types are very unique and closely related to first-person videos, and thus are generally not present in third-person videos like those in SumMe and TvSum dataset. We see that, while both TDCNN and vsLSTM failed to predict such highlight moments, our model was able to produce satisfactory summarization outputs due to the exploitation of information across annotated third and first-person videos (including unlabeled ones).

## 5 Conclusions

In this paper, we proposed a novel deep learning architecture of first-person video summarization. Our network uniquely integrates modules of cross-domain feature embedding and highlight detection in a recurrent framework, which allows the extraction and adaptation of spatiotemporal discriminative highlight information across video domains. Moreover, to alleviate possible overfitting due to a small amount of labeled first-person video data during training, the introduced self-learning scheme further allows us to exploit information observed

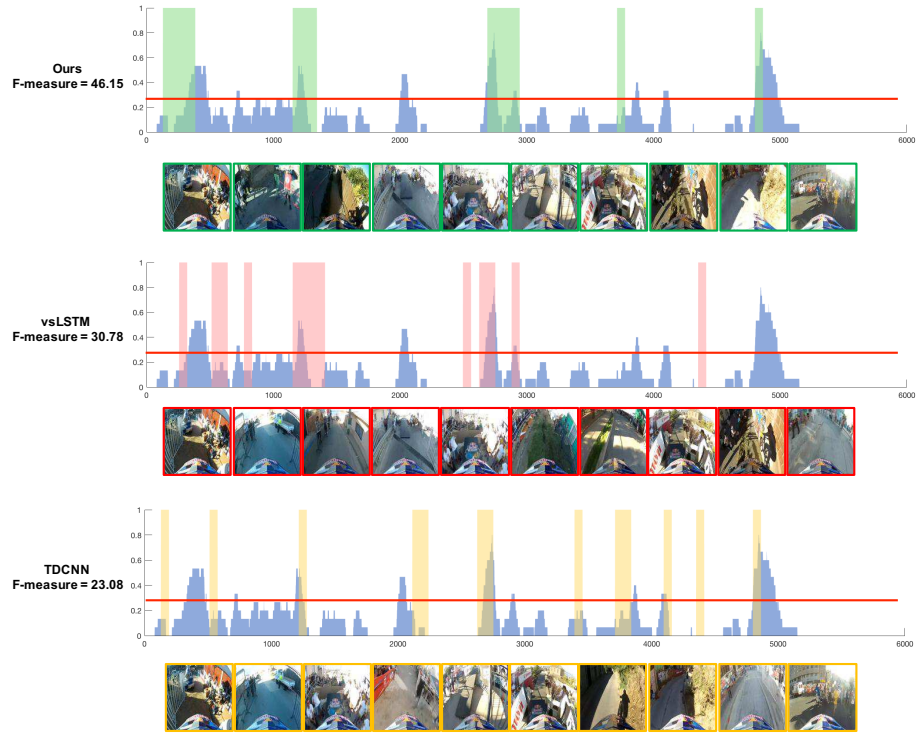

**Fig. 2.** Example summarization results of video “Valparaiso Downhill” from SumMe. The ground-truth annotation scores are shown in blue, while the predicted summaries from our model, vsLSTM, and TDCNN are shown in green, red and yellow, respectively. Note that the red horizontal line indicates the threshold which splits the scores into highlight and non-highlight ones. Note that our method produces desirable results by detecting movements such as “jumping” and “going downstairs”. In contrast, others fail to capture the moments with a large number of false predictions.

from unlabeled first-person videos (i.e., a semi-supervised setting). In addition to evaluation of benchmark datasets, we additionally collect a new first-person video dataset. Quantitative and qualitative experimental results confirmed the effectiveness and robustness of our proposed model for first-person video summarization.

**Acknowledgments** This work was supported in part by the Ministry of Science and Technology of Taiwan under grants MOST 107-2636-E-009-001 and 107-2634-F-002-010.

## References

1. Abu-El-Haija, S., Kothari, N., Lee, J., Natsev, P., Toderici, G., Varadarajan, B., Vijayanarasimhan, S.: Youtube-8m: A large-scale video classification benchmark. arXiv:1609.08675 (2016)
2. Betancourt, A., Morerio, P., Regazzoni, C.S., Rauterberg, M.: The evolution of first person vision methods: A survey. *IEEE Transactions on Circuits and Systems for Video Technology (TCSVT)* **25**(5), 744–760 (2015)
3. Bettadapura, V., Castro, D., Essa, I.: Discovering picturesque highlights from egocentric vacation videos. In: *Proceedings of the IEEE Winter Conference on Applications of Computer Vision (WACV)* (2016)
4. Bolanos, M., Dimiccoli, M., Radeva, P.: Toward storytelling from visual lifelogging: An overview. *IEEE Transactions on Human-Machine System (THMS)* **47**(1), 77–90 (2017)
5. Bousmalis, K., Trigeorgis, G., Silberman, N., Krishnan, D., Erhan, D.: Domain separation networks. In: *Advances in Neural Information Processing Systems (NIPS)* (2016)
6. Fathi, A., Hodgins, J.K., Rehg, J.M.: Social interactions: A first-person perspective. In: *Proceedings of the IEEE Conference on Computer Vision and Pattern Recognition (CVPR)* (2012)
7. Gygli, M., Grabner, H., Riemenschneider, H., Van Gool, L.: Creating summaries from user videos. In: *Proceedings of the European Conference on Computer Vision (ECCV)* (2014)
8. Gygli, M., Grabner, H., Van Gool, L.: Video summarization by learning submodular mixtures of objectives. In: *Proceedings of the IEEE Conference on Computer Vision and Pattern Recognition (CVPR)* (2015)
9. Gygli, M., Song, Y., Cao, L.: Video2gif: Automatic generation of animated gifs from video. In: *Proceedings of the IEEE Conference on Computer Vision and Pattern Recognition (CVPR)* (2016)
10. Hoffer, E., Ailon, N.: Deep metric learning using triplet network. In: *International Workshop on Similarity-Based Pattern Recognition* (2015)
11. Ji, Z., Xiong, K., Pang, Y., Li, X.: Video summarization with attention-based encoder-decoder networks. arXiv:1708.09545 (2017)
12. Krizhevsky, A., Sutskever, I., Hinton, G.E.: Imagenet classification with deep convolutional neural networks. In: *Advances in Neural Information Processing Systems (NIPS)* (2012)
13. Lee, Y.J., Ghosh, J., Grauman, K.: Discovering important people and objects for egocentric video summarization. In: *Proceedings of the IEEE Conference on Computer Vision and Pattern Recognition (CVPR)* (2012)
14. Lee, Y.J., Grauman, K.: Predicting important objects for egocentric video summarization. *International Journal of Computer Vision (IJCV)* **114**(1), 38–55 (2015)
15. Lin, Y.L., Morariu, V.I., Hsu, W.: Summarizing while recording: Context-based highlight detection for egocentric videos. In: *Proceedings of the IEEE International Conference on Computer Vision Workshops* (2015)
16. Lu, Z., Grauman, K.: Story-driven summarization for egocentric video. In: *Proceedings of the IEEE Conference on Computer Vision and Pattern Recognition (CVPR)* (2013)
17. Mahasseni, B., Lam, M., Todorovic, S.: Unsupervised video summarization with adversarial lstm networks. In: *Proceedings of the IEEE Conference on Computer Vision and Pattern Recognition (CVPR)* (2017)

18. del Molino, A.G., Tan, C., Lim, J.H., Tan, A.H.: Summarization of egocentric videos: A comprehensive survey. *IEEE Transactions on Human-Machine Systems* **47**(1), 65–76 (2017)
19. Pan, S.J., Yang, Q.: A survey on transfer learning. *IEEE Transactions on Knowledge and Data Engineering (TKDE)* **22**(10), 1345–1359 (2010)
20. Panda, R., Das, A., Wu, Z., Ernst, J., Roy-Chowdhury, A.K.: Weakly supervised summarization of web videos. In: *Proceedings of the IEEE International Conference on Computer Vision (ICCV)* (2017)
21. Patel, V.M., Gopalan, R., Li, R., Chellappa, R.: Visual domain adaptation: A survey of recent advances. *IEEE Signal Processing Magazine* **32**(3), 53–69 (2015)
22. Sermanet, P., Lynch, C., Chebotar, Y., Hsu, J., Jang, E., Schaal, S., Levine, S.: Time-contrastive networks: Self-supervised learning from video. *Proceedings of the IEEE International Conference on Robotics and Automation (ICRA)* (2018), <http://arxiv.org/abs/1704.06888>
23. Song, Y., Vallmitjana, J., Stent, A., Jaimes, A.: Tvsum: Summarizing web videos using titles. In: *Proceedings of the IEEE Conference on Computer Vision and Pattern Recognition (CVPR)* (2015)
24. Sun, M., Farhadi, A., Seitz, S.: Ranking domain-specific highlights by analyzing edited videos. In: *Proceedings of the European Conference on Computer Vision (ECCV)* (2014)
25. Szegedy, C., Liu, W., Jia, Y., Sermanet, P., Reed, S., Anguelov, D., Erhan, D., Vanhoucke, V., Rabinovich, A.: Going deeper with convolutions. In: *Proceedings of the IEEE Conference on Computer Vision and Pattern Recognition (CVPR)* (2015)
26. Tran, D., Bourdev, L., Fergus, R., Torresani, L., Paluri, M.: Learning spatiotemporal features with 3d convolutional networks. In: *Proceedings of the IEEE International Conference on Computer Vision (ICCV)* (2015)
27. Xu, J., Mukherjee, L., Li, Y., Warner, J., Rehg, J.M., Singh, V.: Gaze-enabled egocentric video summarization via constrained submodular maximization. In: *Proceedings of the IEEE Conference on Computer Vision and Pattern Recognition (CVPR)* (2015)
28. Yao, T., Mei, T., Rui, Y.: Highlight detection with pairwise deep ranking for first-person video summarization. In: *Proceedings of the IEEE Conference on Computer Vision and Pattern Recognition (CVPR)* (2016)
29. Yeung, S., Fathi, A., Fei-Fei, L.: Videoset: Video summary evaluation through text. [arXiv:1406.5824](https://arxiv.org/abs/1406.5824) (2014)
30. Zhang, K., Chao, W.L., Sha, F., Grauman, K.: Video summarization with long short-term memory. In: *Proceedings of the European Conference on Computer Vision (ECCV)* (2016)